

ECOBLOC® 10-40-10 HEVF

GREATER EFFICIENCY WITH THE ECOBLOC® VERSION

In addition to being available as a stand-alone machine, the EBS KL stretch-blow moulders can also be combined with an Enoberg filler and a capper into a single machine.

This results in the ECOBLOC® ERGON, an ultra-compact solution where the rinser and the conveyors between the stretch-blow moulder and the filler are not required, minimizing the risks of product contamination and eliminating the causes of line inefficiency.

This system is suitable for several sectors: flat and carbonated water, fresh milk, juices, edible oil, vinegar, CSD and detergents.

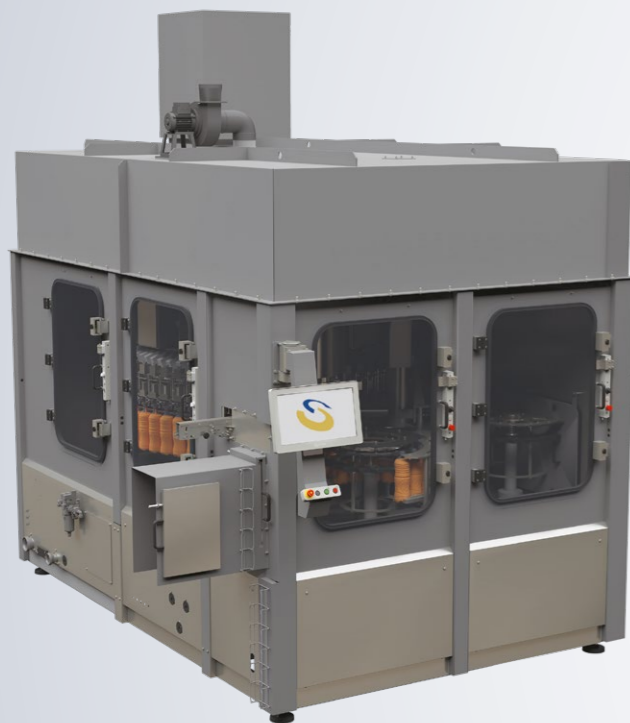

HYPER-CLEAN ELECTRONIC FILLERS

The electronic filling systems by ENOBERG, company part of the SMI Group, are characterized by a high operational flexibility and are capable of meeting the market requirements in terms of hygiene, reliability, ease of use and maintenance. They can handle a wide range of products: the HEVF range can bottle still water, iced tea, juice, milk, vinegar, syrups, sauces, detergents and sanitizers; the HEMF series is suitable for oil and the HEVS range can process carbonated water and CSDs.

The filling process is extremely precise, thanks to the use of the flowmeter, an electronic device installed near each valve that detects the flow of the product that fills each bottle by counting the pulses and sends a closure sign to the filling valve, once the value of the format in use is reached.

Fillers are available as a stand-alone machine or in a combi-version, solutions for stretch-blow moulding, filling and capping rPET/PET and PP containers.

ELECTRONIC CAPPER

The electronic capper is one of the latest innovations from SMI's R&D department. This cam-free machine uses a single motor to control both the vertical movement and rotation of the capping head. Each station can reach speeds of up to 2,400 bottles per hour, ensuring high precision and reliable performance. Designed for maximum versatility, it can handle containers of various shapes and sizes.



SMART TECHNOLOGY THAT TAKES CARE OF EVERY DROP



EBS 10 KL rotary stretch-blow moulder & HEVF Hyper-clean electronic filler

www.smigroup.it



SMI S.p.A.
Via Carlo Ceresa, 10
I-24015 San Giovanni Bianco (BG)
Tel.: +39 0345 40.111
Fax: +39 0345 40.209
E-mail: info@smigroup.it

NEW EBS 10 KL

SHAPING THE FUTURE OF BOTTLING

High performance, compact design and low operating costs, three core qualities combined in one smart solution: the EBS KL ERGON stretch-blow moulder. Designed for producing PET and rPET bottles of any shape and size up to 3 L, this machine is ideal for the beverage industry, delivering outputs of up to 2,750 bottles per hour per cavity.

For large-format containers, the EBS KL range is also available in the HC version, designed to produce bottles from 3 to 10 litres, with a maximum output of 1,500 bottles per hour per cavity. The HC models come in 3, 4, and 6-cavity configurations, offering flexibility for a wide range of production needs.

MODEL	MAXIMUM OUTPUT (0.5/0.75 L bottles)
EBS 4 KL	11,000 bottles per hour
EBS 6 KL	16,500 bottles per hour
EBS 8 KL	22,000 bottles per hour
EBS 10 KL	27,500 bottles per hour

MODEL	MAXIMUM OUTPUT (3/5 L bottles)
EBS 3 KL HC	4,500 bottles per hour
EBS 4 KL HC	6,000 bottles per hour
EBS 6 KL HC	9,000 bottles per hour



EASY TRANSPORT, INSTALLATION AND MAINTENANCE

Small size can make a big difference. That's why SMI has developed a stretch-blow moulder that fits perfectly into compact bottling lines, can be easily transported in a standard container and is designed for fast installation and easy maintenance.

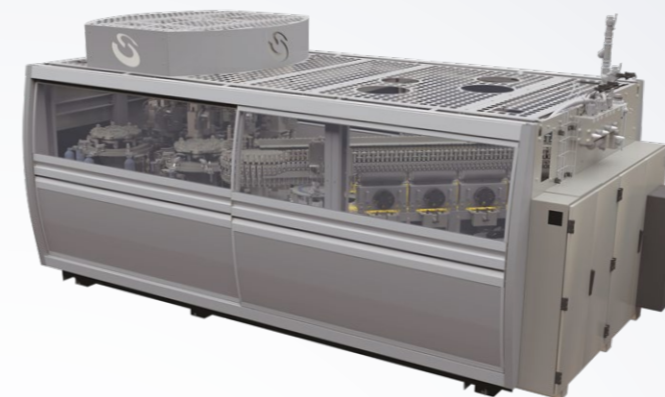

ENERGY SAVING

Energy efficiency translates into real savings. The EBS KL series achieves this thanks to several smart features: the motorized stretch rods on the blowing carousel are controlled by electronic drives rather than pneumatic cams, ensuring greater precision, while eliminating the need for compressed air. An integrated energy meter monitors consumption in real time, while the infrared lamp-equipped heating tunnel also boasts high-efficiency ceramic panels. The EBS KL blow moulder is also equipped with the AirMaster recovery system, which enables to recover air from the blowing circuit, reducing compressed air consumption up to 40% compared to the systems that are not equipped with it.

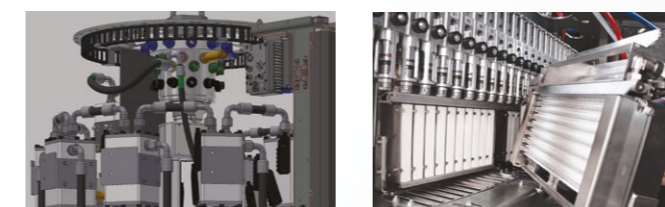

FAST FORMAT CHANGEOVER

Format changeover operations are quick and straightforward thanks to numeric position indicators and a cam-free preform feeding system, which reduce downtime and improve operational flexibility.



HIGH QUALITY BOTTLES

Bottle quality is ensured by a new ventilation system, which lowers the temperature of the preform neck, thus optimizing thickness and eliminating ovalization and deformation, and by the use of low dead volume valves, which help reduce pre-blowing and blowing times.

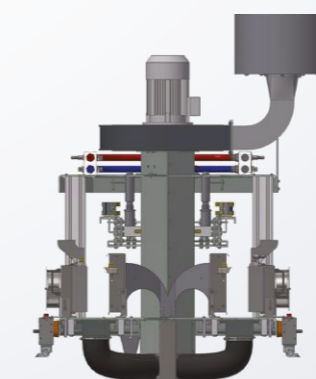

INNOVATION-FULL... LABEL-LESS

Label-free packaging is one of the most forward-thinking trends in the PET and rPET beverage market.

More and more brands are adopting it to reduce environmental impact, simplify production and stand out on the shelf.

SMI supports companies on this path by providing advanced solutions for the design and production of label-free containers, such as the one manufactured by the blow moulder on display.

Choosing label-free bottles means embracing a circular economy approach: no labels, inks, or adhesives make recycling easier and more efficient.

Their clean, minimal design enhances product appeal, strengthens brand identity and delivers a sleek, modern look.

From a production standpoint, label-free bottles streamline bottling lines, eliminating labelling machines and reducing material consumption and maintenance costs.



LABEL-LESS BOTTLE
scan this QR code



ECOBLOC®
3D VIDEO
scan this QR code